

## Complex Data Acquisition System Uses Few Components

Richard Markell

### Introduction

Sophisticated filter system designs frequently demand expensive printed circuit boards chock-full of operational amplifiers and precision capacitors. Digital filters require fewer but more expensive devices and a lot of software. However, advances in switched capacitor filters have made the design of elegant filter systems cheaper, easier and much smaller. The system shown in block diagram form in Figure 1 is a good example. It is a typical system for filtering transducer signals. Its input is a DC-to-20kHz signal; its output allows signals to be analyzed in three frequency bands.

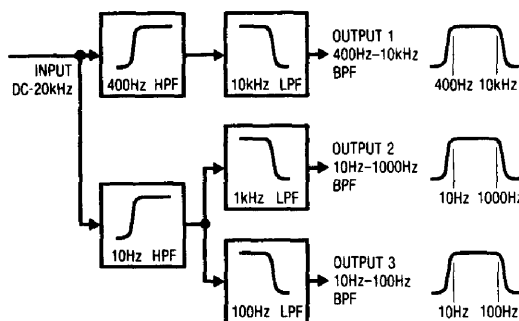

Figure 1. Filter System Block Diagram

### Implementation

A system implemented using switched capacitor filters is shown in schematic form in Figure 2. This implementation uses two LTC1064 quad switched capacitor building blocks and one LTC1062 5th order Butterworth lowpass filter. The system requires the use of one operational amplifier, an LT1007.

### Filter Design Specifications and Test Results

**Filter 1** — a 400Hz-to-10kHz bandpass filter, with passband ripple of 1dB and passband noise of  $200\mu\text{VRMS}$ , Figure 3.

**Filter 2** — a 10Hz-to-100Hz bandpass filter, with passband ripple of 1dB and passband noise of  $500\mu\text{VRMS}$ , Figure 4.

**Filter 3** — a 10Hz-to-1kHz bandpass filter, with passband ripple of 1dB and passband noise of  $390\mu\text{VRMS}$ , Figure 5.

These wideband filters are made by cascading 4th order elliptic lowpass and highpass filters. The single exception is the 5th order Butterworth lowpass filter used in the 400Hz-to-10kHz section.

### System Considerations

The LTC1064 quad switched capacitor filters used are building blocks capable of implementing up to 8th order filters. One LTC1064 implements both a 4-pole elliptic 400Hz highpass filter and a 4-pole elliptic 1kHz lowpass filter. The other LTC1064 implements a 4-pole elliptic 100Hz lowpass filter and a 4-pole elliptic 10Hz highpass filter. The LTC1062 is a 5-pole Butterworth lowpass filter set at 10kHz.

Resistors  $R_{11A}$  to  $R_{H2A}$  implement the 400Hz elliptic highpass filter in Device A. The 1kHz elliptic lowpass filter in Device A is implemented by  $R_{13A}$  to  $R_{44A}$ . Resistors  $R_{11B1}$  to  $R_{42B}$  implement the 10Hz elliptic highpass filter in Device B. The 100Hz elliptic lowpass filter in Device B is implemented by  $R_{13B}$  through  $R_{44B}$ . The LTC1062 is hardware programmed for 10kHz by  $R_{50}$  and  $C_{50}$ .

The 8th order LTC1064 devices allow the use of two sections in the 100:1 clock-to-center frequency mode and two sections in the 50:1 mode. (Resistor programming can then be used to further extend the clock-to-center frequency range to 25:1 for two sections and 250:1 for the other two sections.) This allows decade-wide bandpass filters to be built using only one LTC1064 at one clock frequency.

### Conclusion

This is only one use of the new switched capacitor building blocks, the LTC1064 family of quad switched capacitor filters. These filters have wide flexibility. For example, the 10Hz-to-100Hz filter could be used at 20Hz-to-200Hz simply by doubling the clock, which sets the filter frequency. Similarly, bands of interest could be inspected by sweeping the clock. The devices work with center frequencies as high as 100kHz in circuits with similar simplicity.

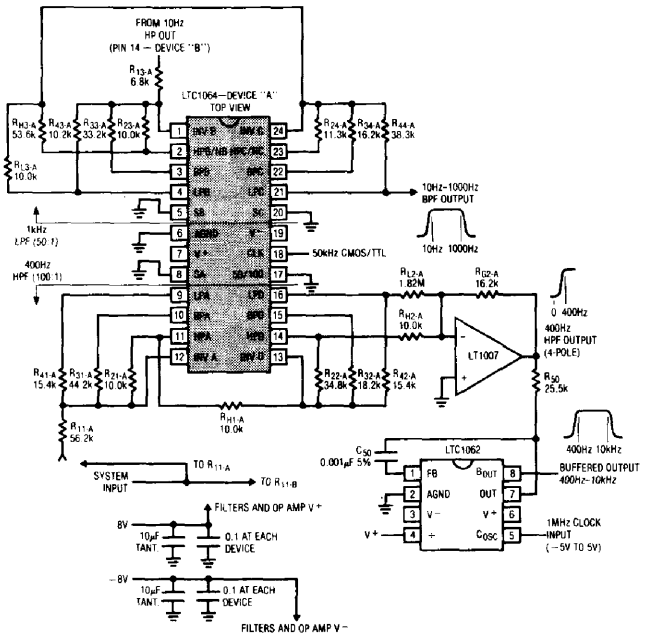

Figure 2. Schematic Diagram

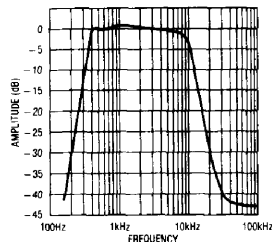

Figure 3. 400Hz-10kHz BP Filter Amplitude Response

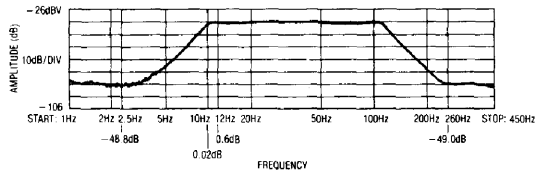
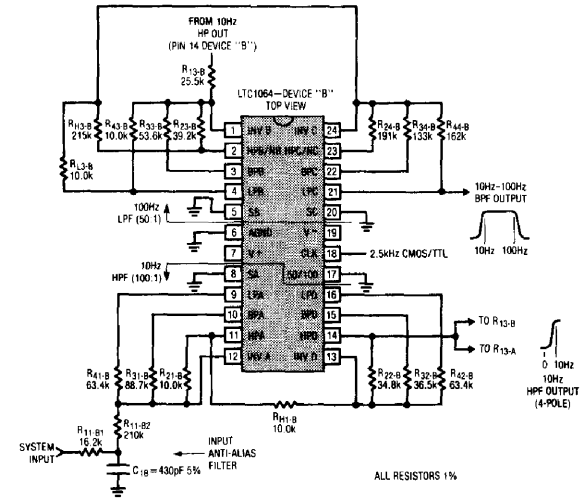

Figure 4. 10Hz-100Hz BPF Amplitude Response

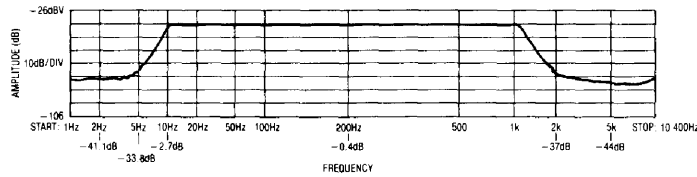

Figure 5. 10Hz-1000Hz BPF Amplitude Response

For literature on our complete filter line, call (800) 637-5545. For applications help, call (408) 432-1900, Ext. 453.